

middenweg 4

MIDDENWEG 4 - FASE 1

01.07.2015

opdrachtgever:
Woonwaard
gebruiker:
Esdégé Reigersdaal





situatietekening

concept terreininrichting

het appartement

plattegronden / doorsnedes cluster

plattegrond / doorsnede activiteitencentrum

visualisaties

materialisatie

TEKENINGEN EN VISUALISATIES TER ILLUSTRATIE EN AANGEGEVEN MAATVOERING INDICATIEF



concept terreininrichting

MIDDENWEG 4 - FASE 1

01.07.2015

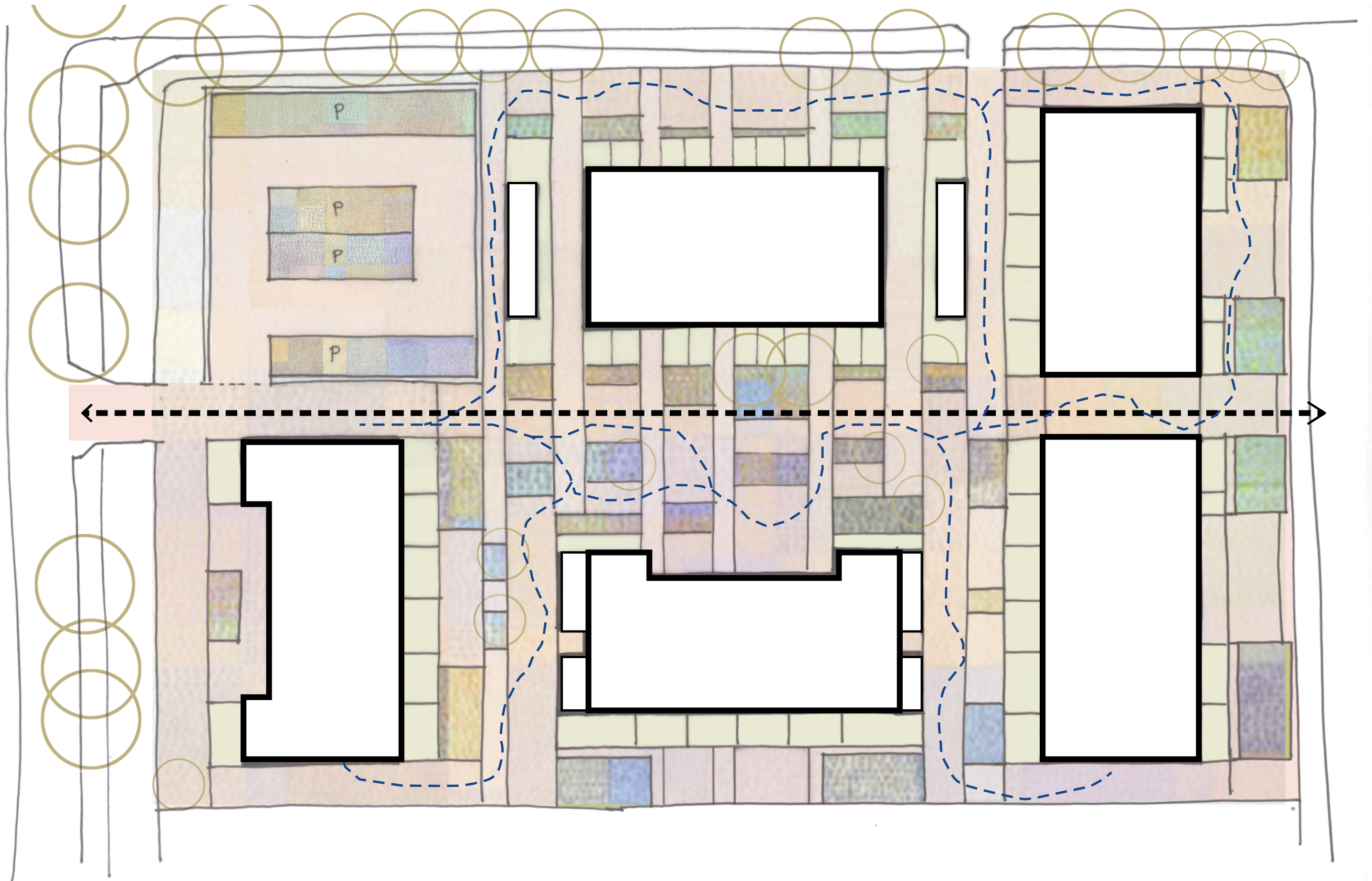



AANGEGEVEN MAATVOERING INDICATIEF, TEKENING D1.0 EN D2.0 FASE 1 DD. 01.07.2015 GEVEN DE MAATVOERING WEER

het appartement

MIDDENWEG 4 - FASE 1

01.07.2015

TEKENINGEN EN VISUALISATIES TER ILLUSTRATIE EN AANGEGEVEN MAATVOERING INDICATIEF

het appartement

MIDDENWEG 4 - FASE 1

01.07.2015

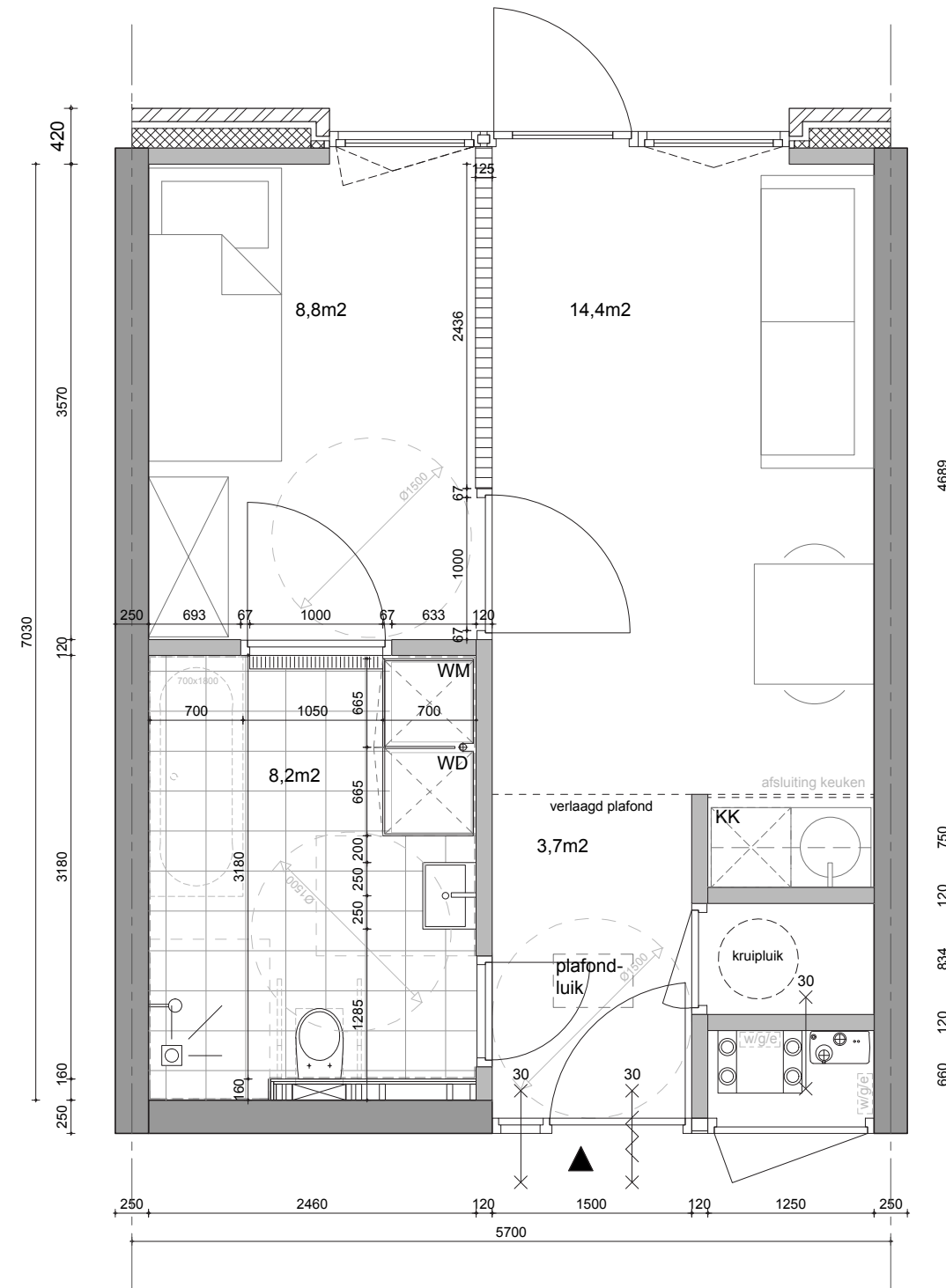

AANGEGEVEN MAATVOERING INDICATIEF

TEKENINGEN EN VISUALISATIES TER ILLUSTRATIE EN AANGEGEVEN MAATVOERING INDICATIEF

AANGEGEVEN MAATVOERING INDICATIEF

cluster 1A

MIDDENWEG 4 - FASE 1

01.07.2015

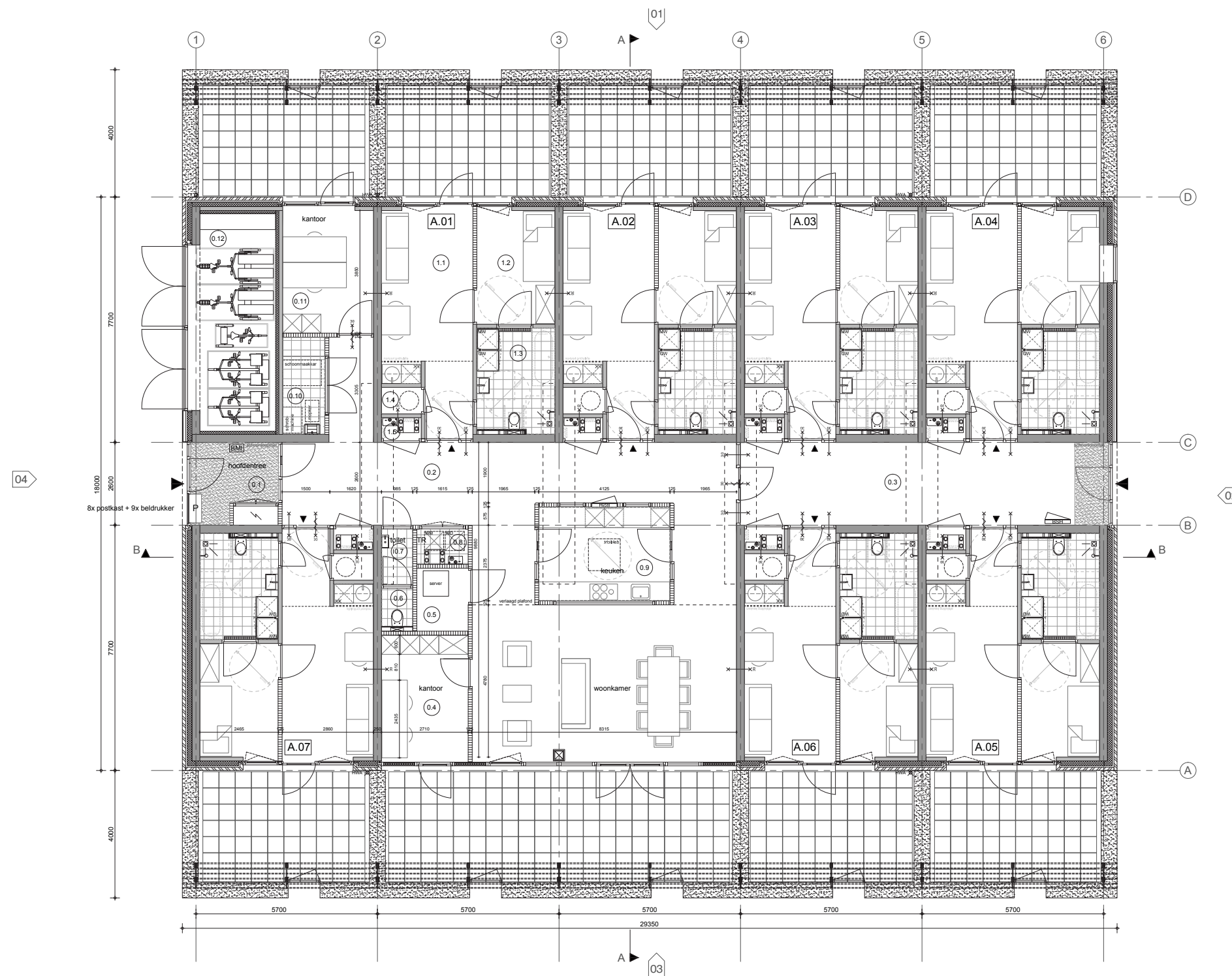

AANGEGEVEN MAATVOERING INDICATIEF

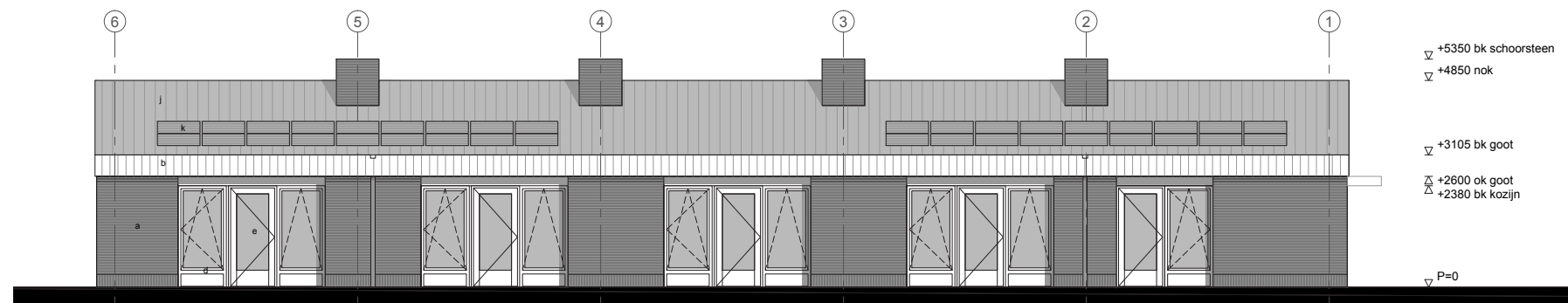

gevelaanzicht 01

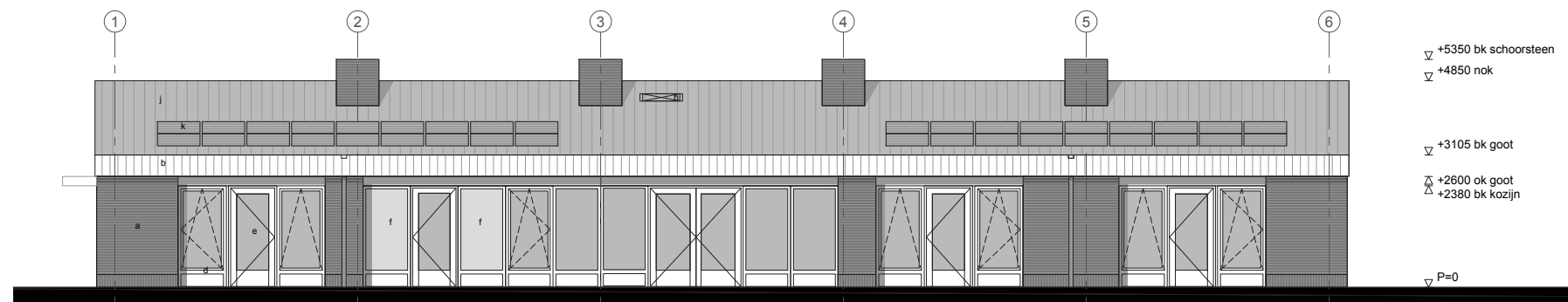

gevelaanzicht 03

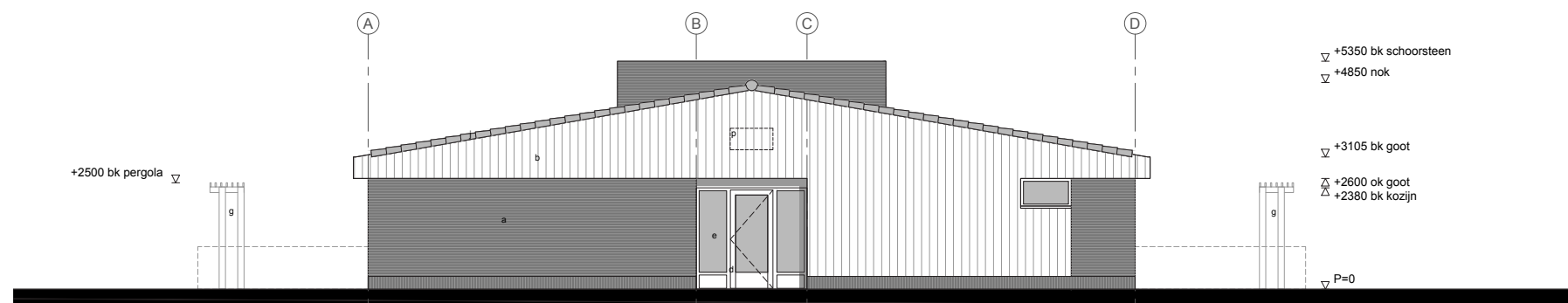

gevelaanzicht 02

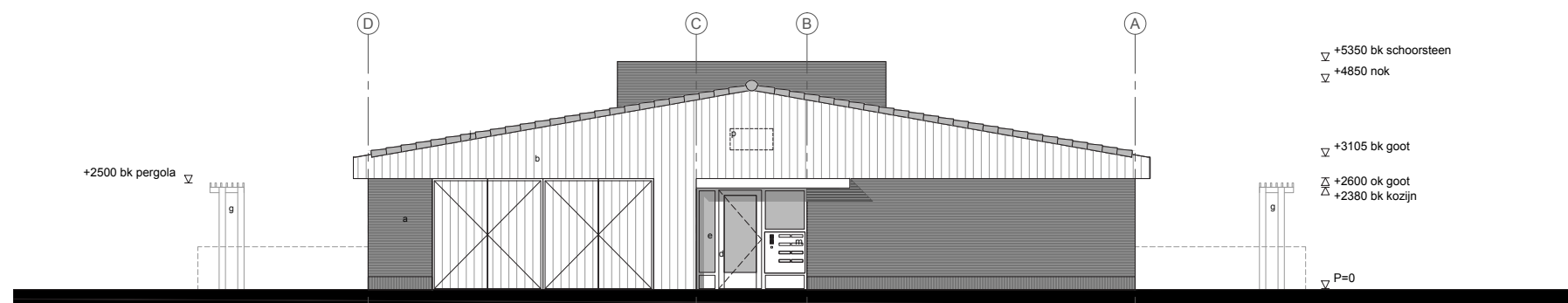

gevelaanzicht 04

AANGEGEVEN MAATVOERING INDICATIEF

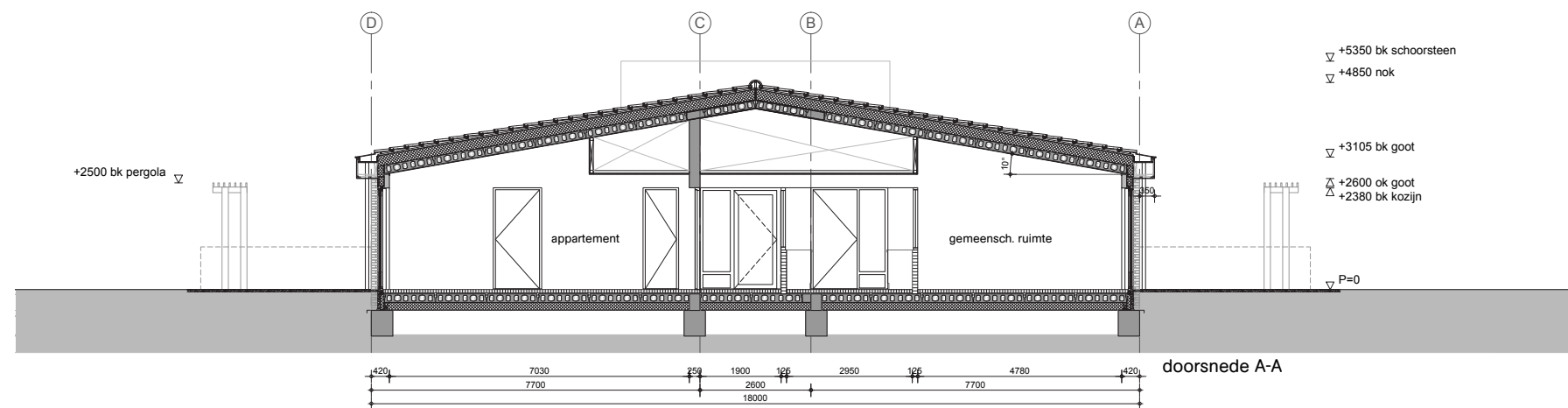
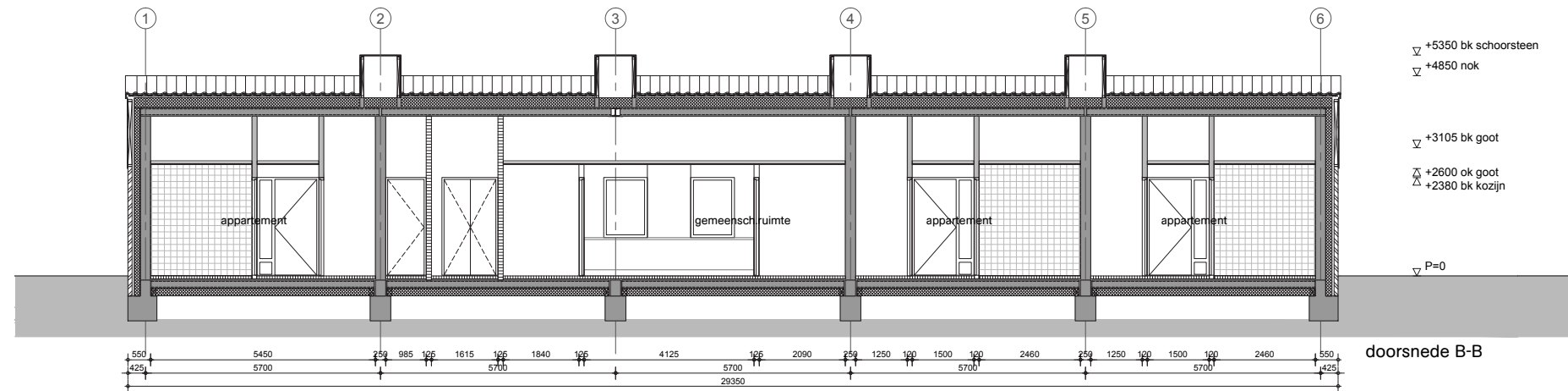

AANGEGEVEN MAATVOERING INDICATIEF

TEKENINGEN EN VISUALISATIES TER ILLUSTRATIE EN AANGEGEVEN MAATVOERING INDICATIEF

AANGEGEVEN MAATVOERING INDICATIEF

cluster 1B

MIDDENWEG 4 - FASE 1

01.07.2015

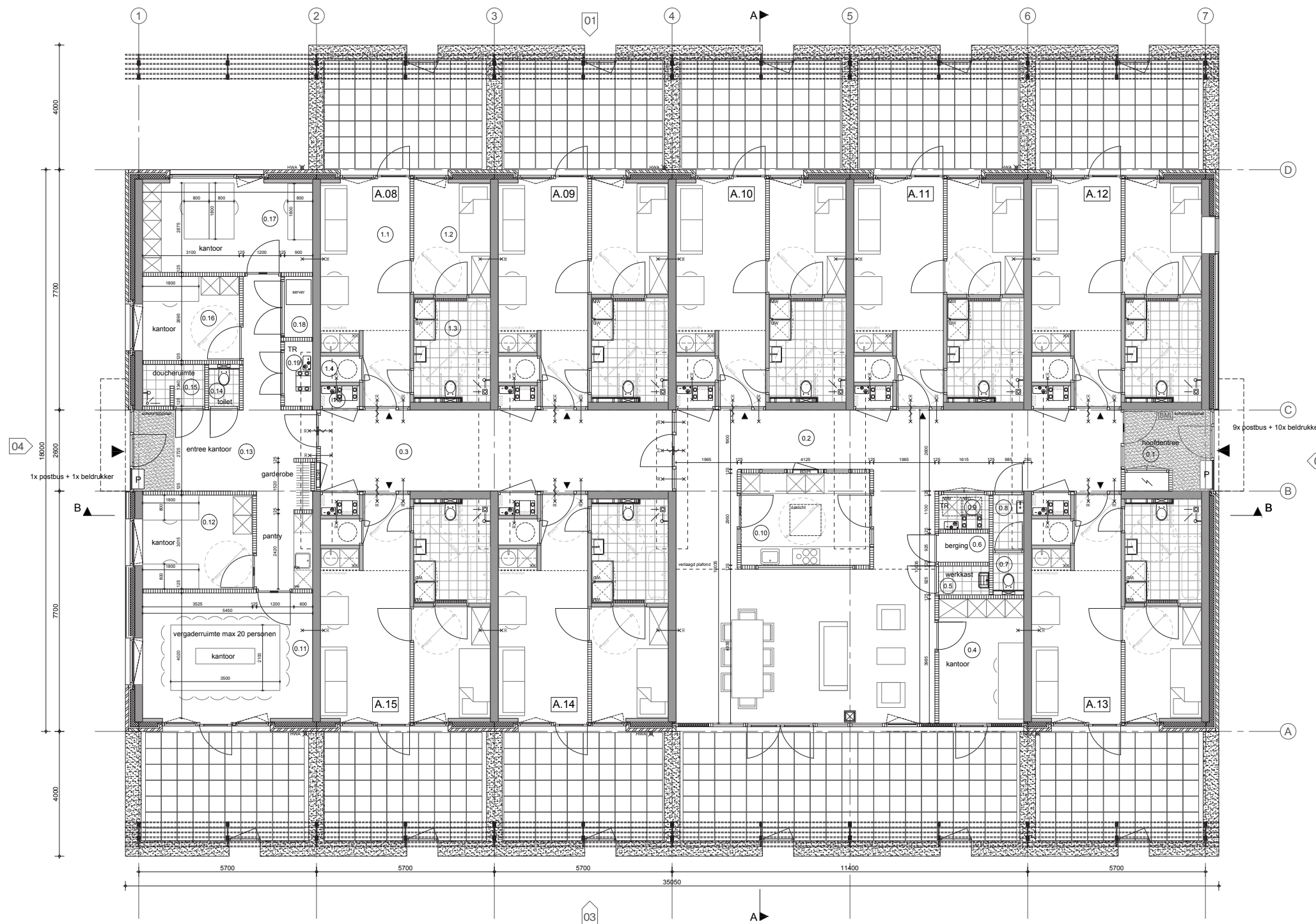

AANGEGEVEN MAATVOERING INDICATIEF

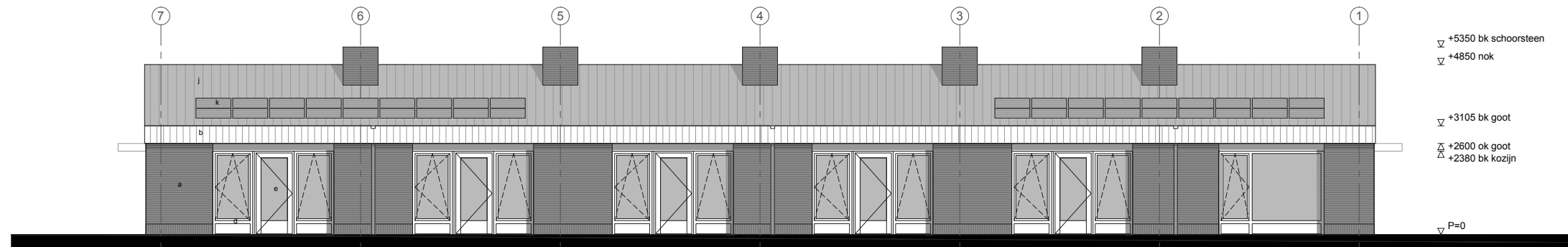

gevelaanzicht 01

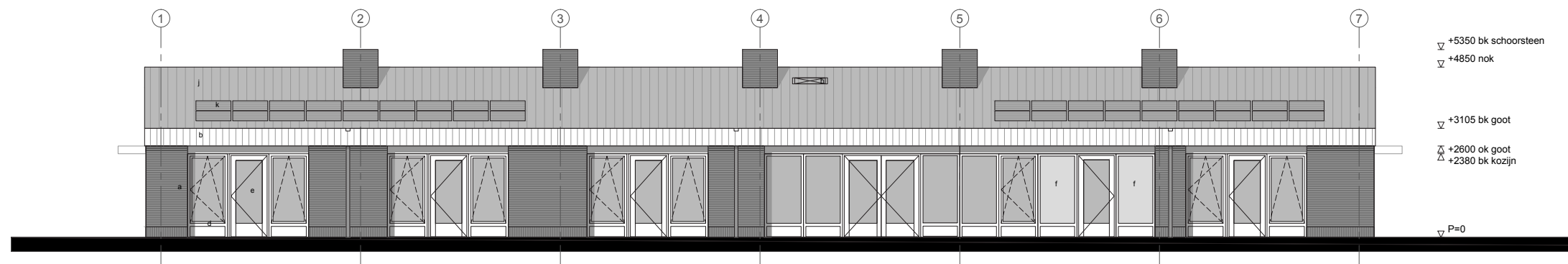

gevelaanzicht 03

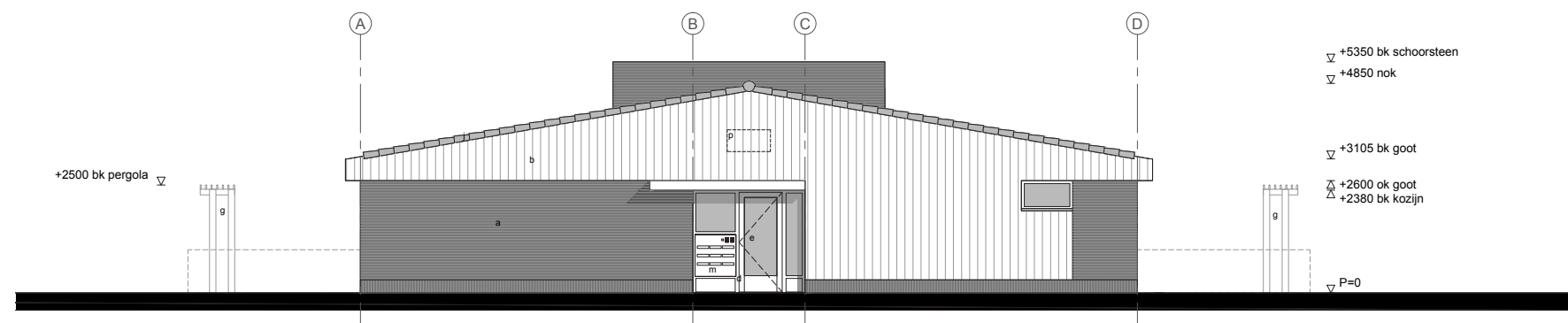

gevelaanzicht 02

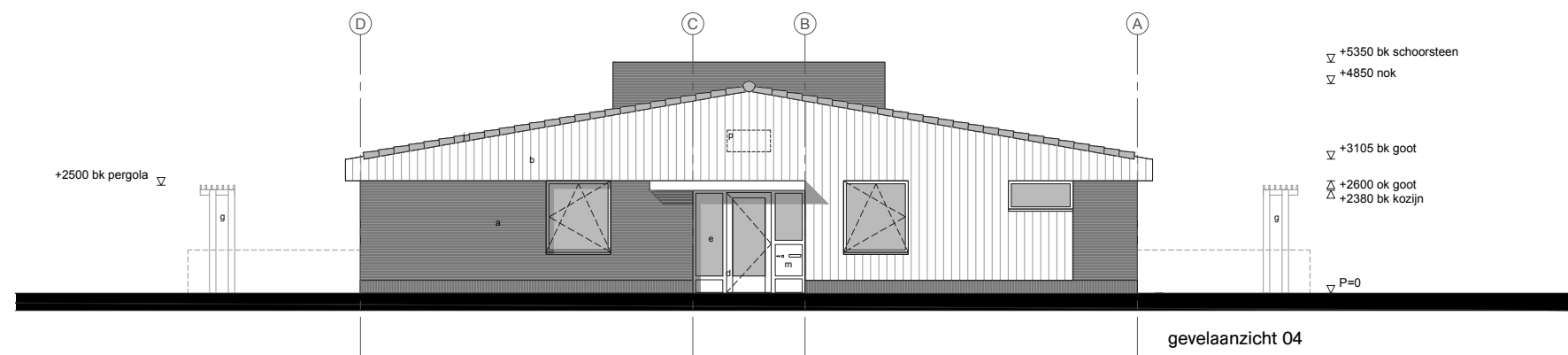

gevelaanzicht 04

AANGEGEVEN MAATVOERING INDICATIEF

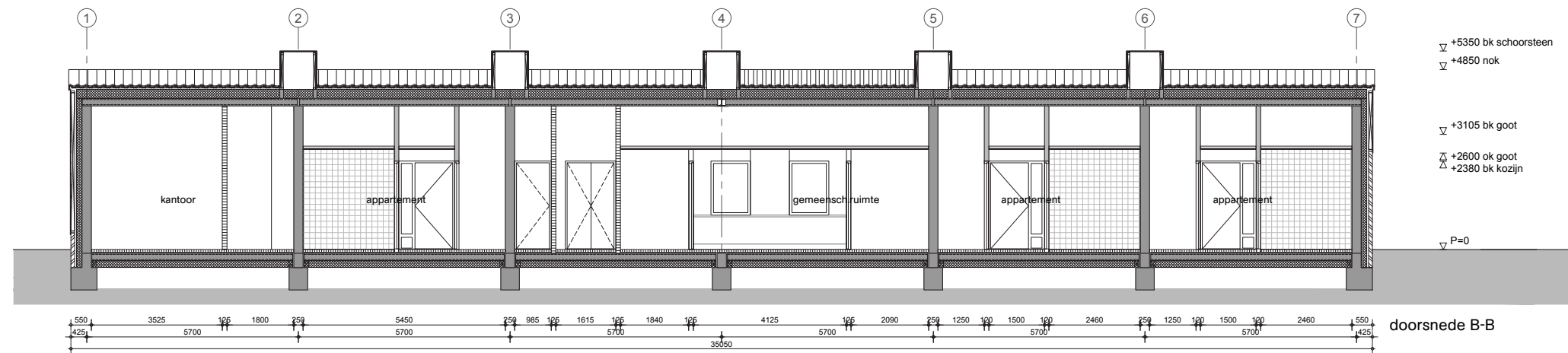

doorsnede B-B

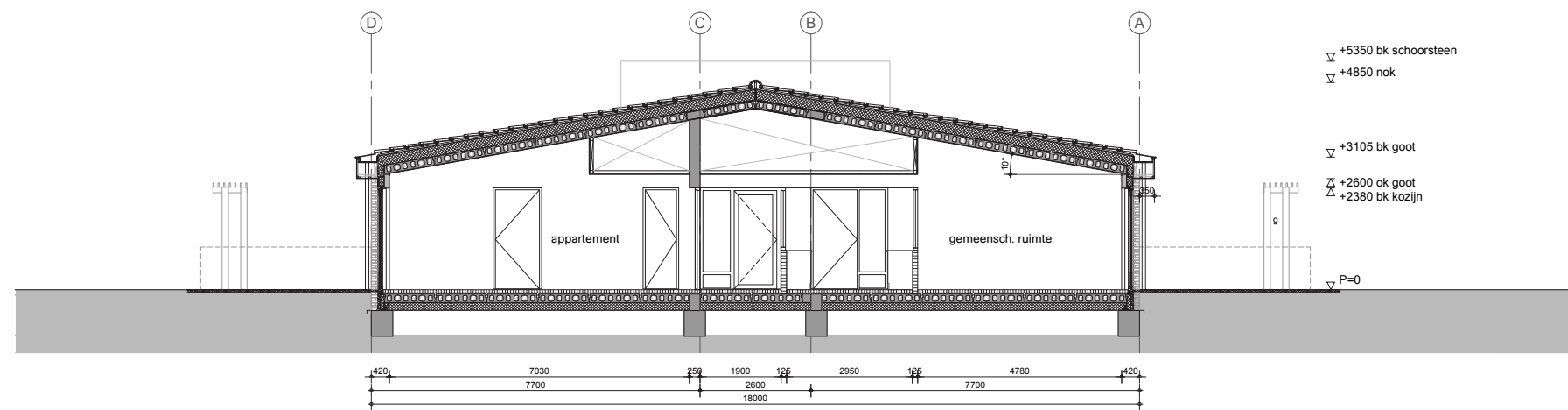

doorsnede A-A

AANGEGEVEN MAATVOERING INDICATIEF

TEKENINGEN EN VISUALISATIES TER ILLUSTRATIE EN AANGEGEVEN MAATVOERING INDICATIEF

AANGEGEVEN MAATVOERING INDICATIEF

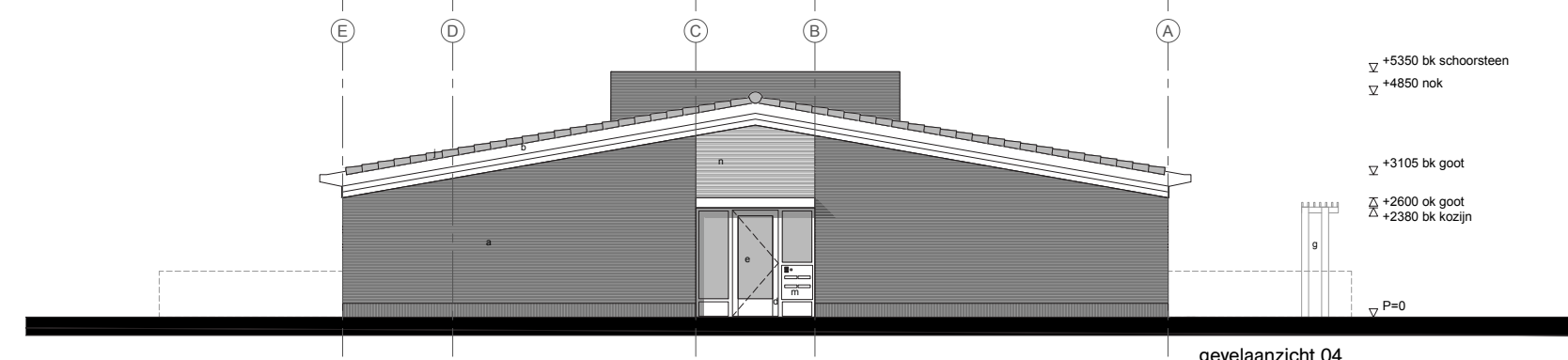
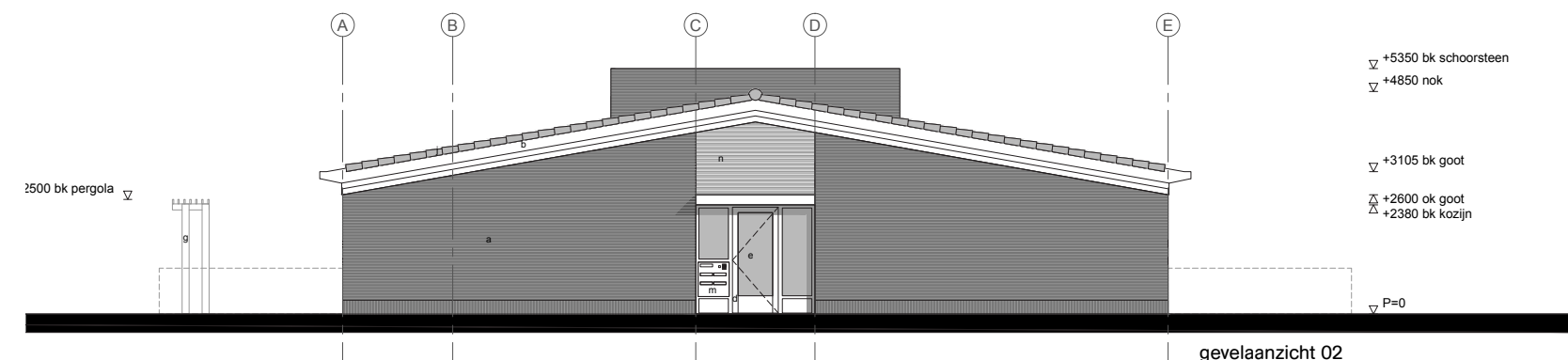
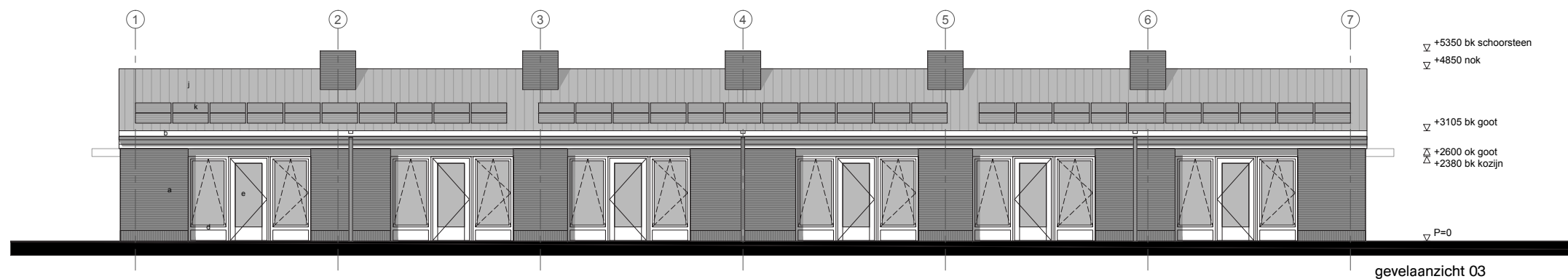
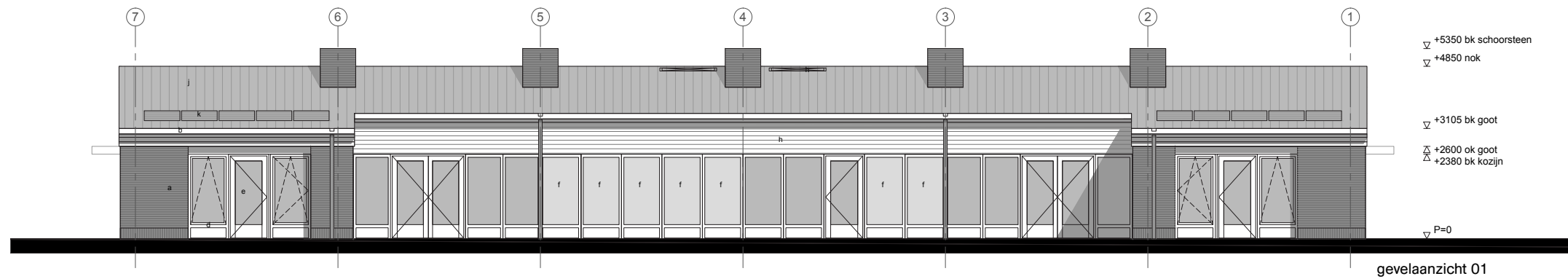

AANGEGEVEN MAATVOERING INDICATIEF

cluster 2A

MIDDENWEG 4 - FASE 1

01.07.2015

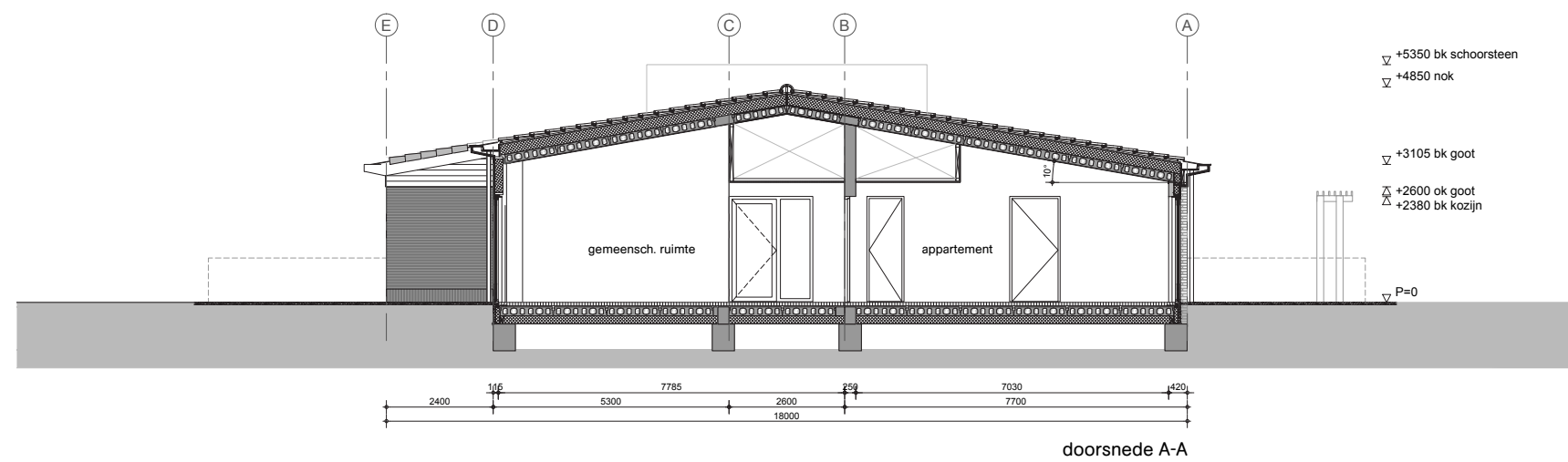
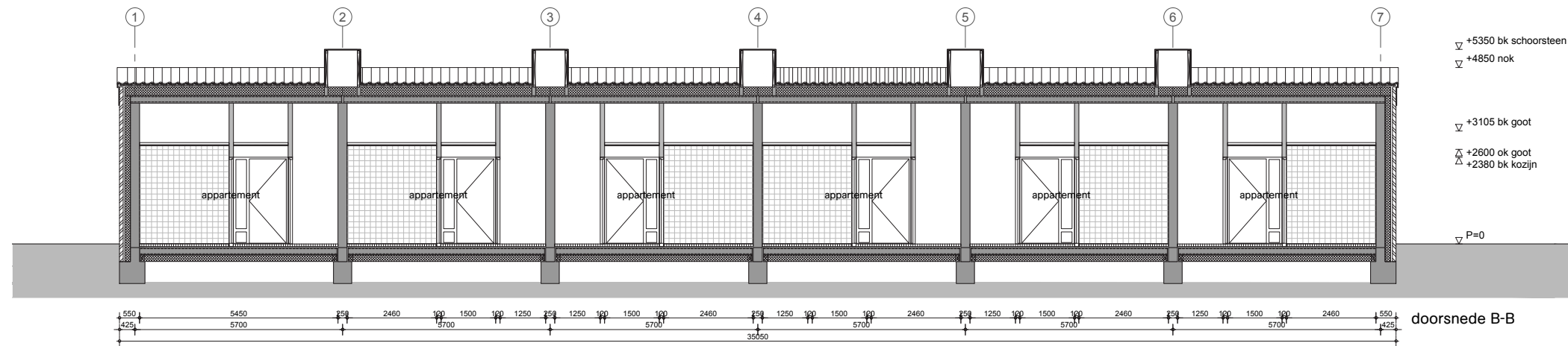

AANGEGEVEN MAATVOERING INDICATIEF

TEKENINGEN EN VISUALISATIES TER ILLUSTRATIE EN AANGEGEVEN MAATVOERING INDICATIEF

AANGEGEVEN MAATVOERING INDICATIEF

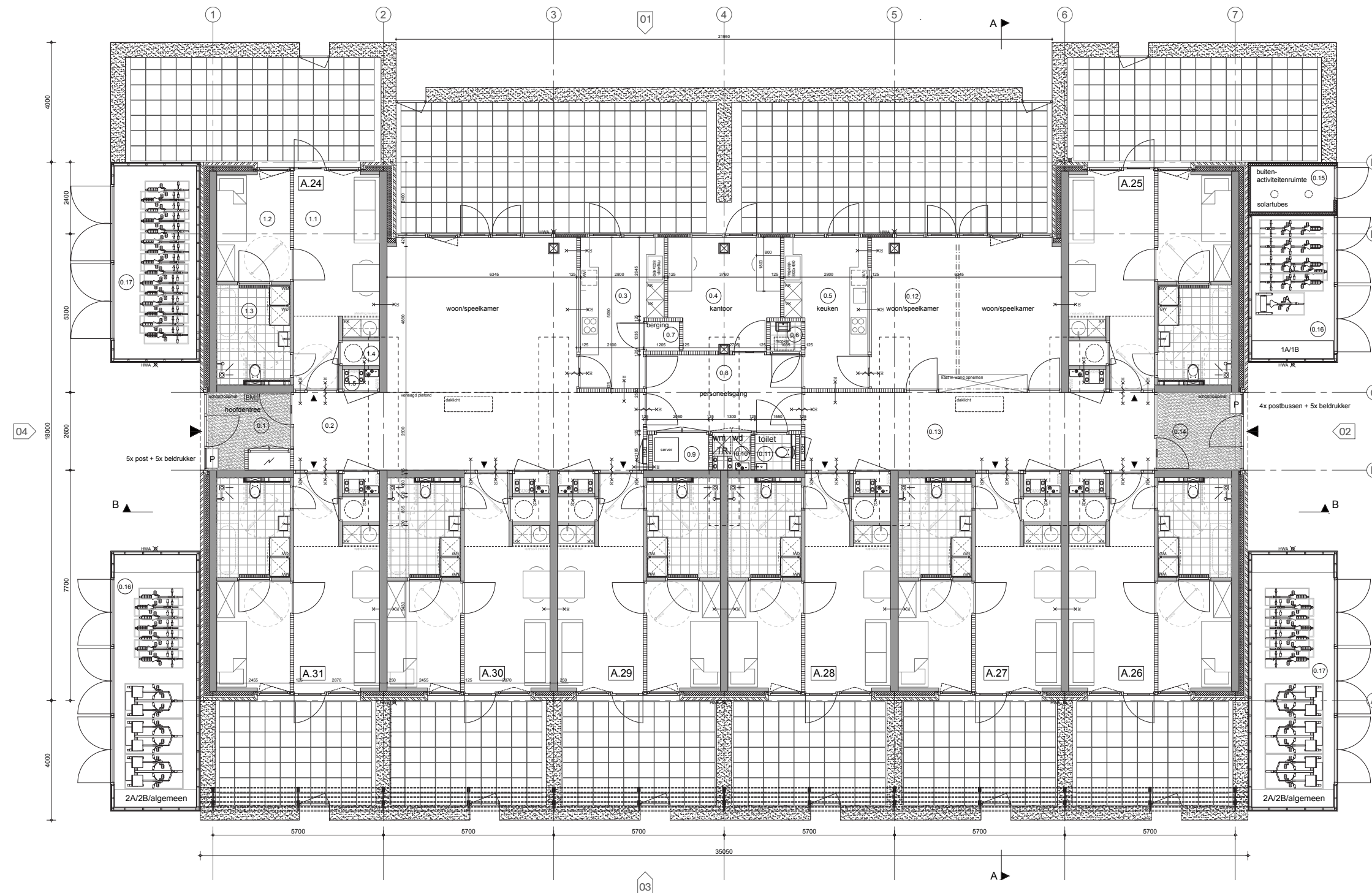

AANGEGEVEN MAATVOERING INDICATIEF

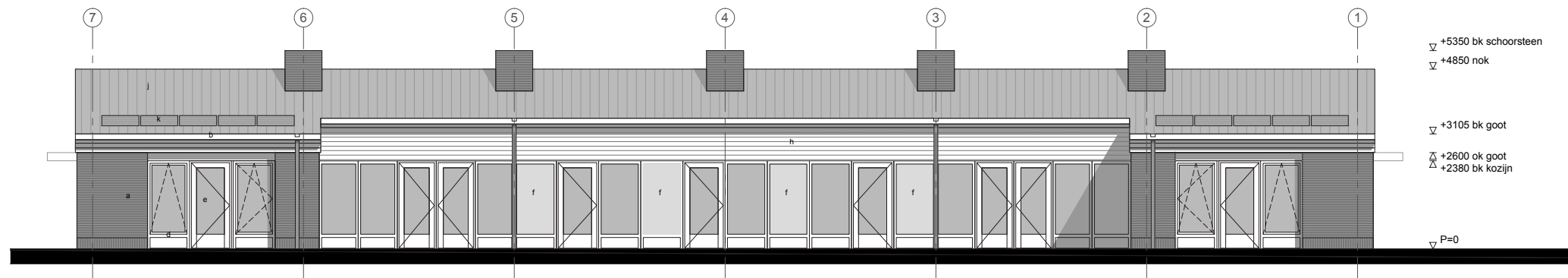

gevelaanzicht 01

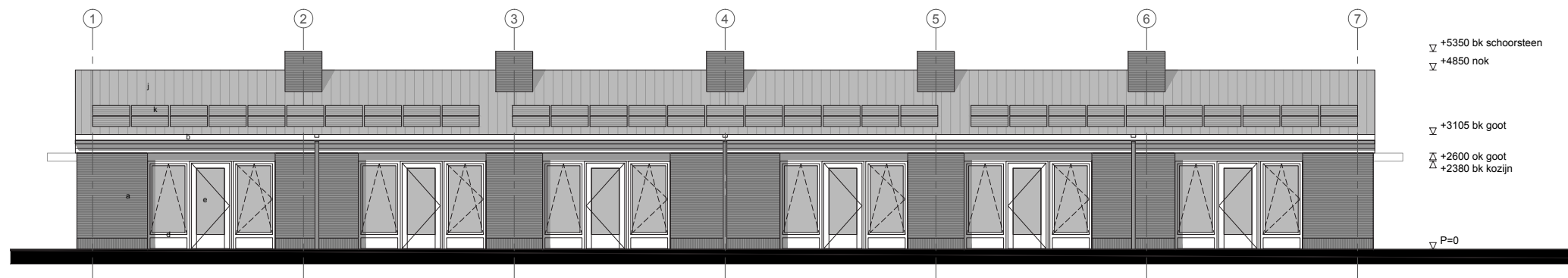

gevelaanzicht 03

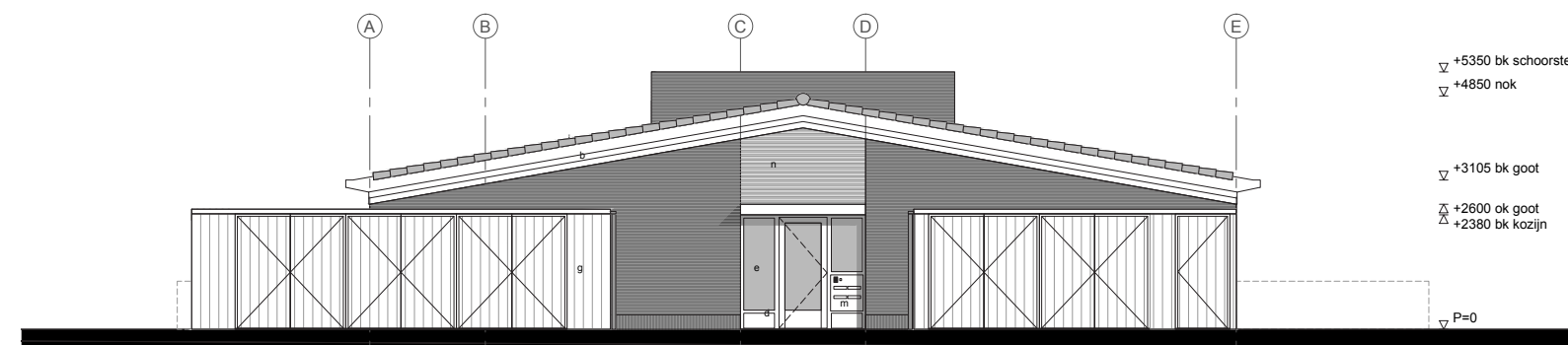

gevelaanzicht 02

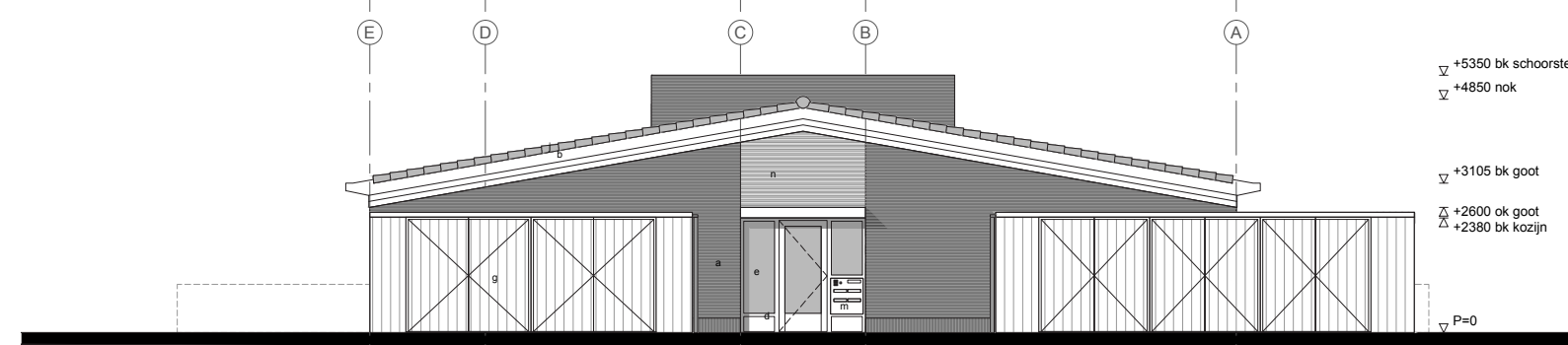

gevelaanzicht 04

AANGEGEVEN MAATVOERING INDICATIEF

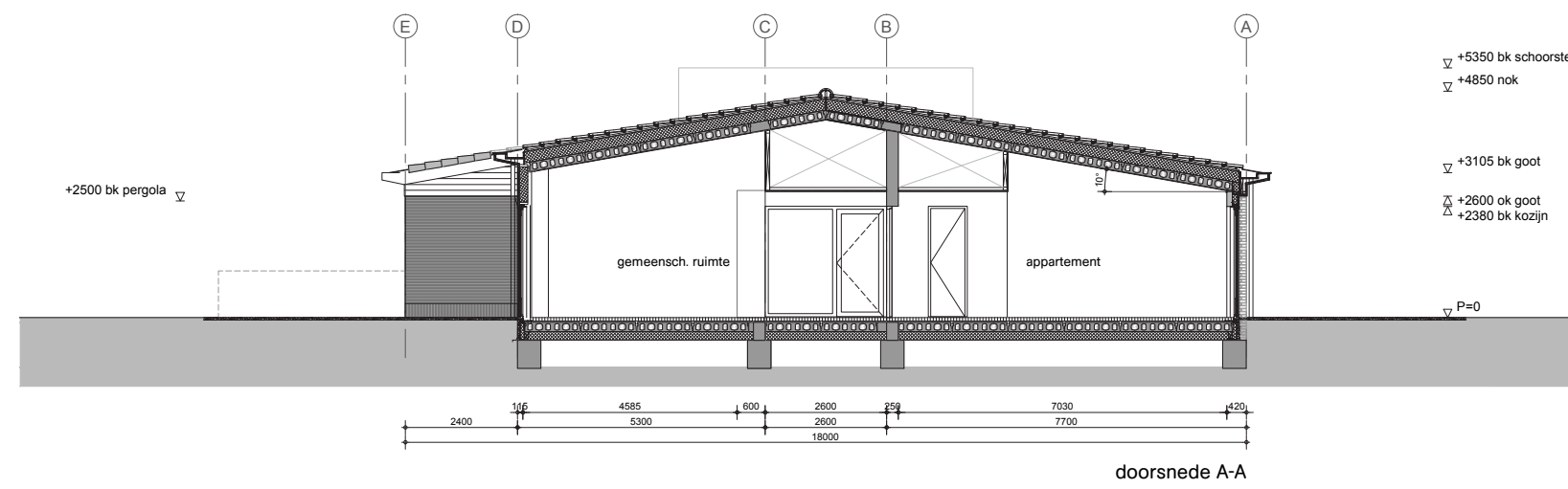
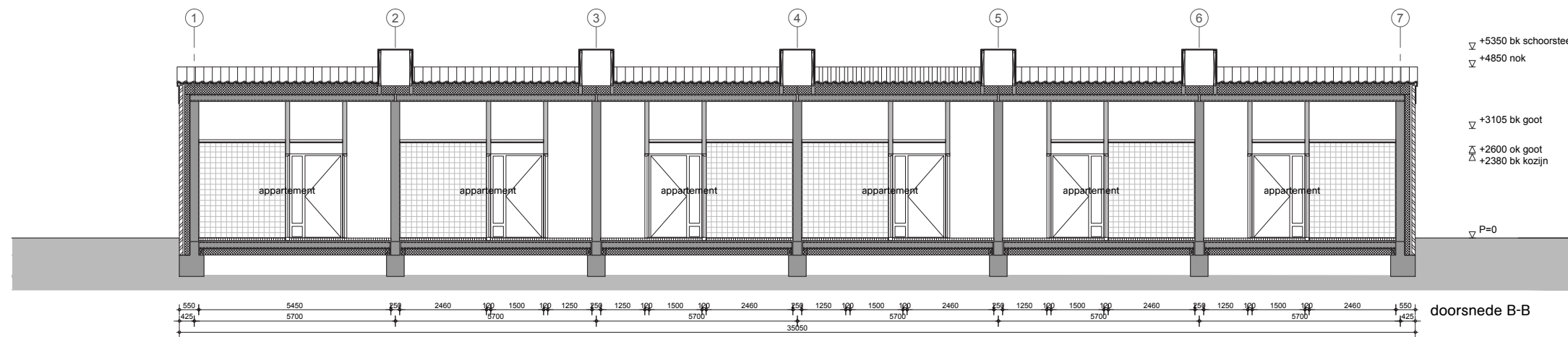

AANGEGEVEN MAATVOERING INDICATIEF

TEKENINGEN EN VISUALISATIES TER ILLUSTRATIE EN AANGEGEVEN MAATVOERING INDICATIEF

AANGEGEVEN MAATVOERING INDICATIEF

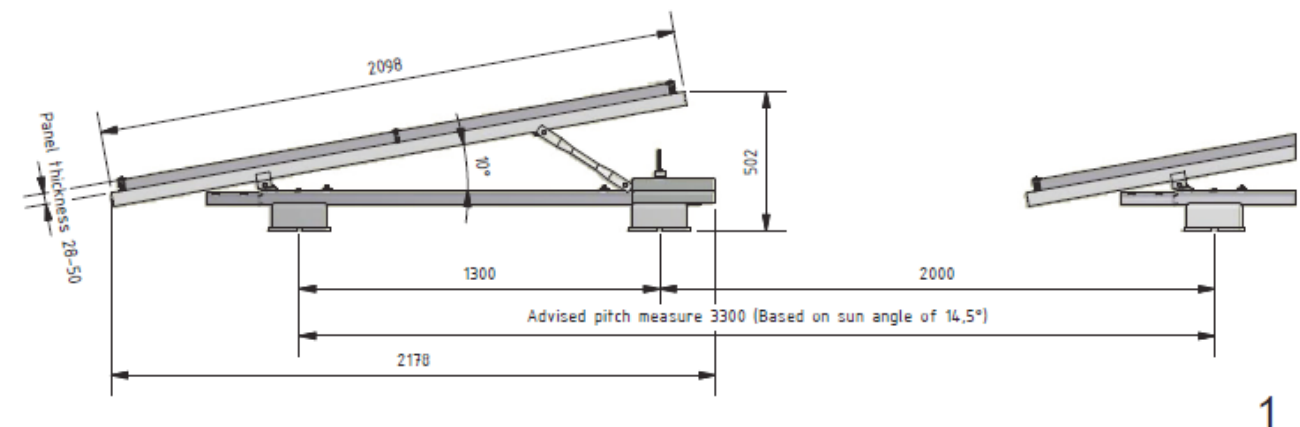
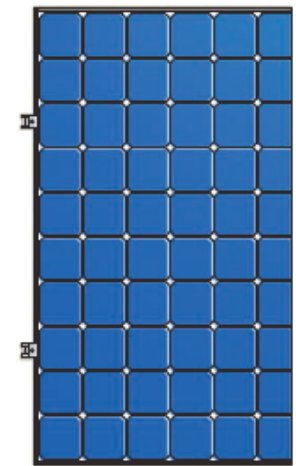
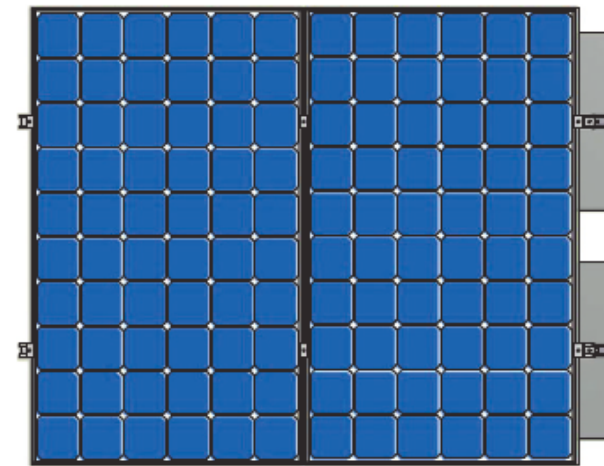
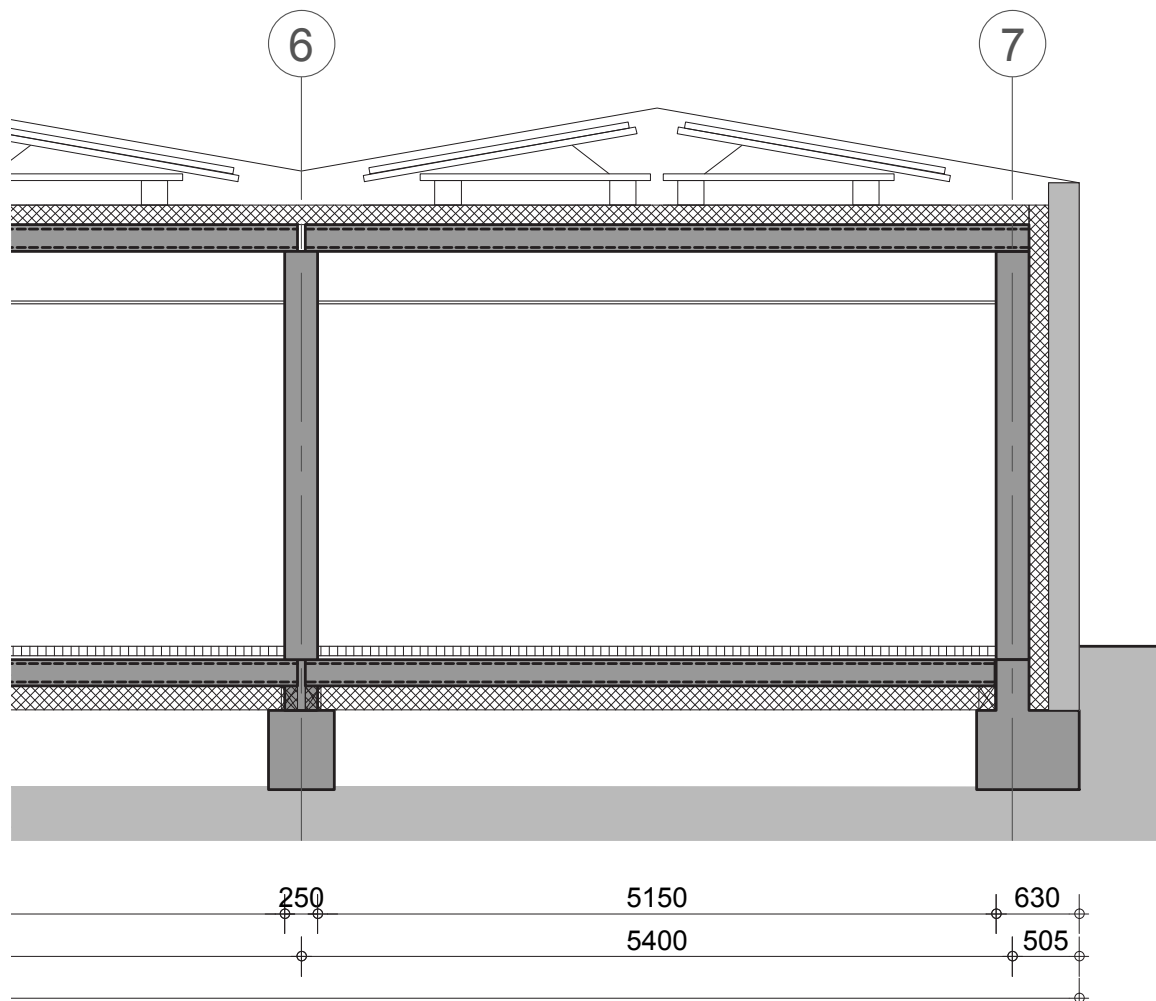

AANGEGEVEN MAATVOERING INDICATIEF

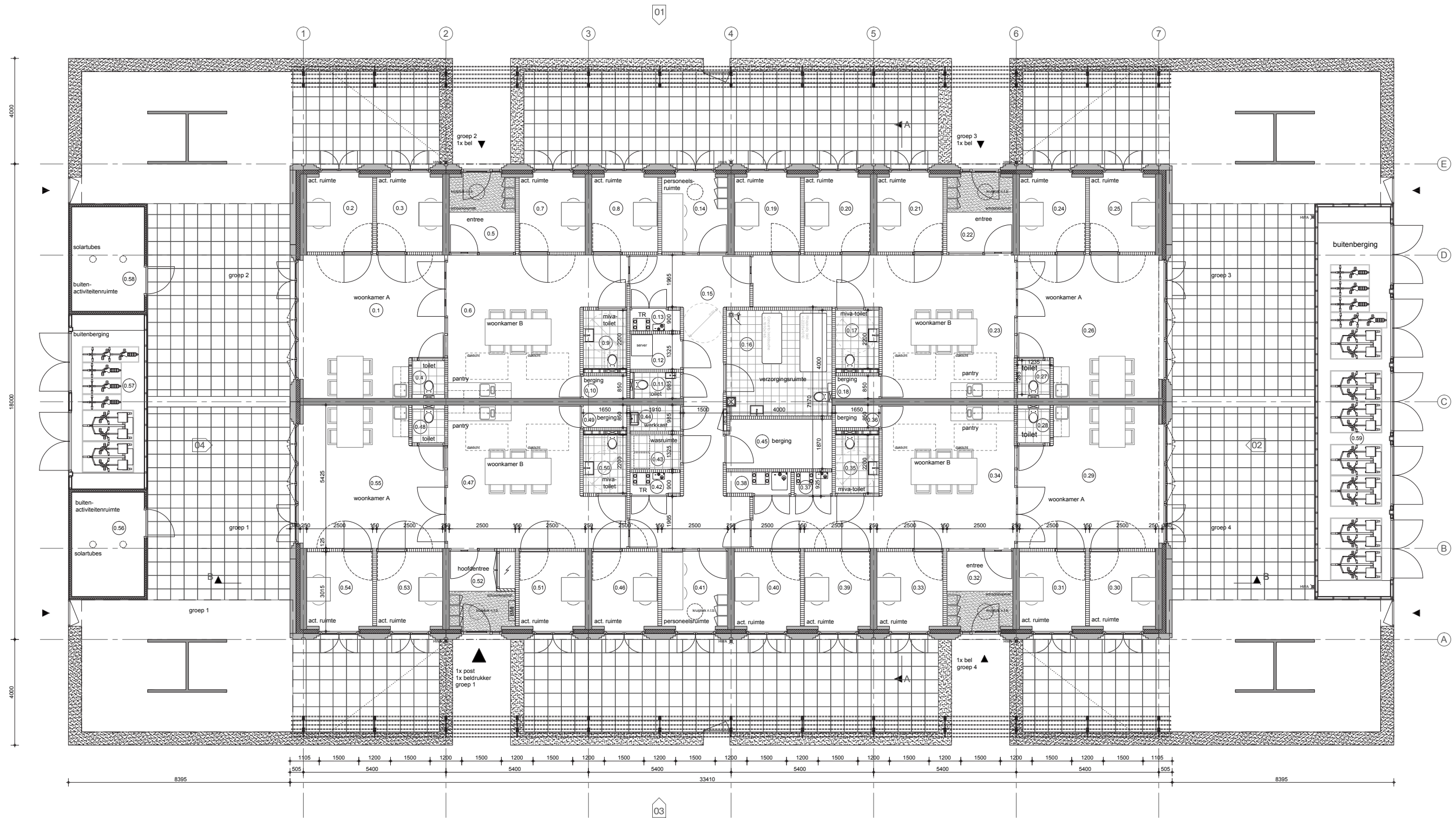

AANGEGEVEN MAATVOERING INDICATIEF

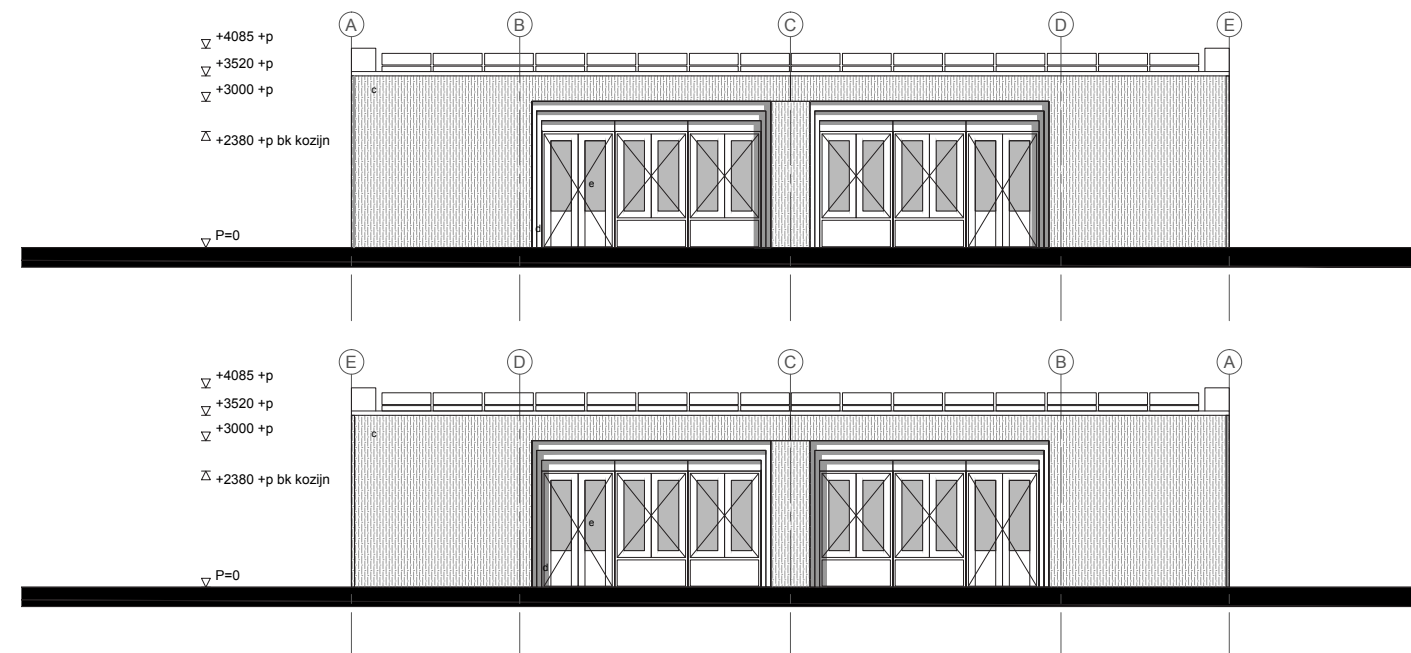
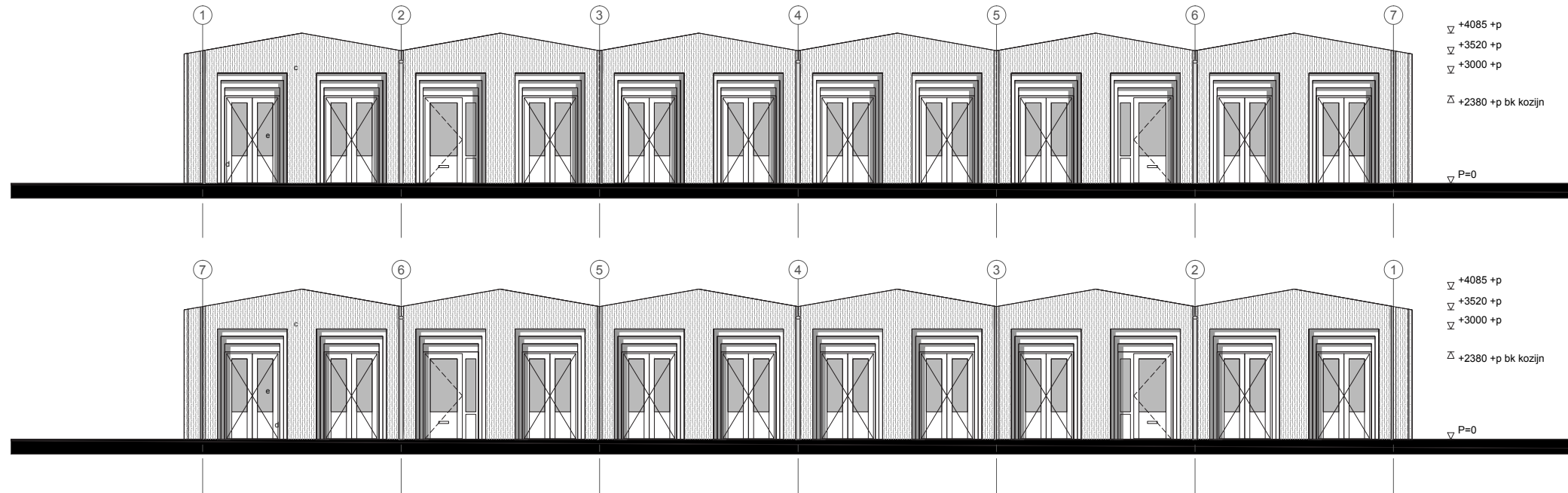

AANGEGEVEN MAATVOERING INDICATIEF

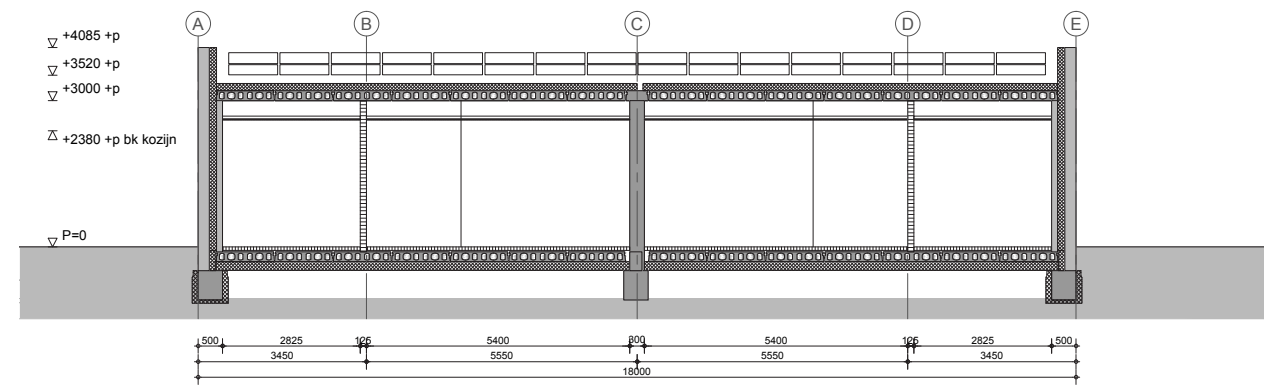
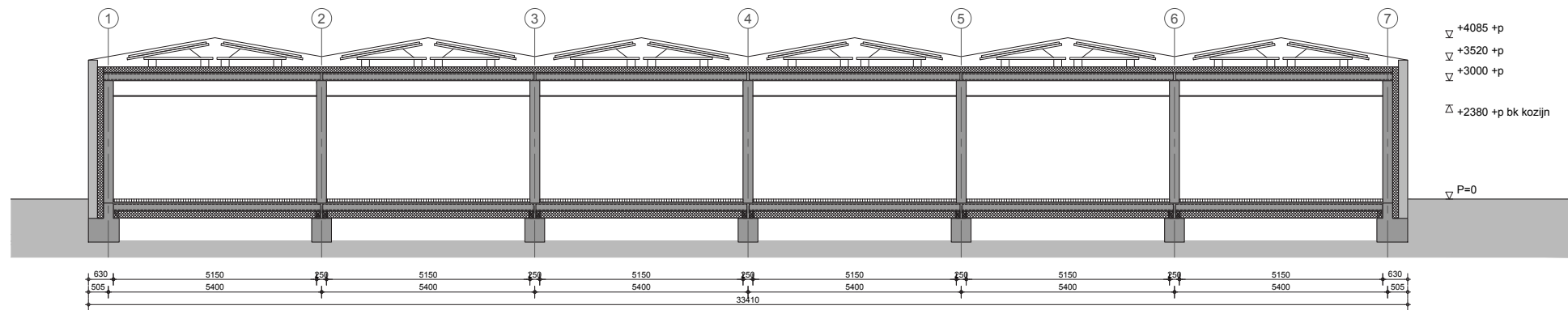

AANGEGEVEN MAATVOERING INDICATIEF

TEKENINGEN EN VISUALISATIES TER ILLUSTRATIE EN AANGEGEVEN MAATVOERING INDICATIEF









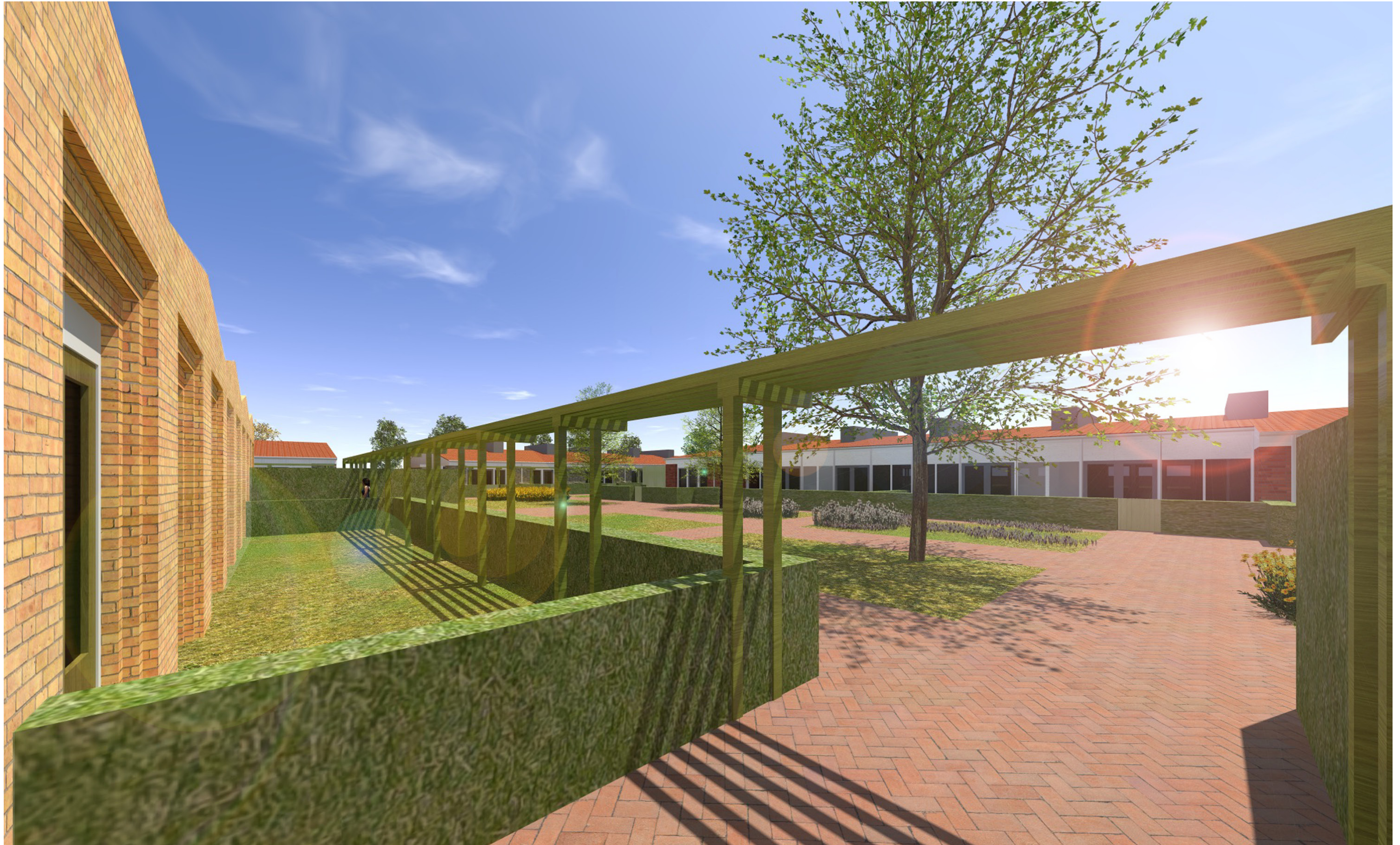













TEKENINGEN EN VISUALISATIES TER ILLUSTRATIE EN AANGEGEVEN MAATVOERING INDICATIEF

materialisatie 1A / 1B

MIDDENWEG 4 - FASE 1

01.07.2015



metselwerk, handvorm

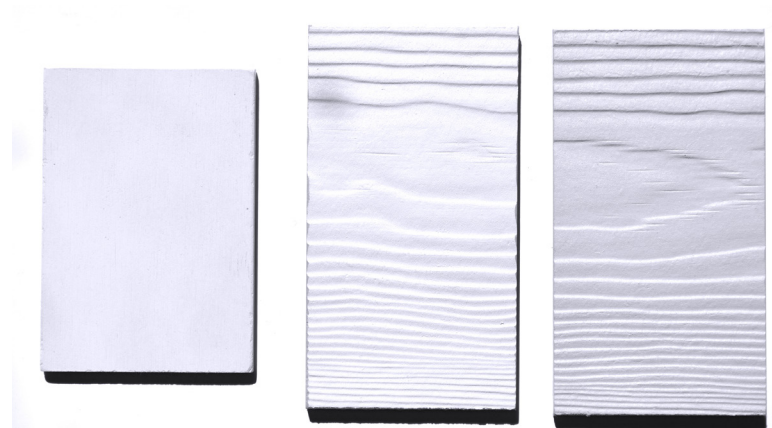

eternit, cedral



hout in kleur

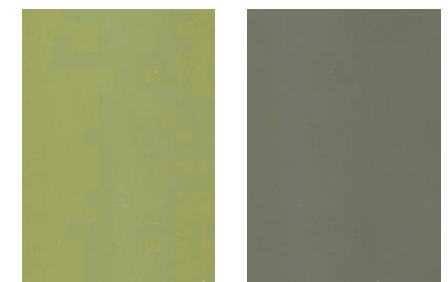

keramische pan,
oudrood en natuurrood

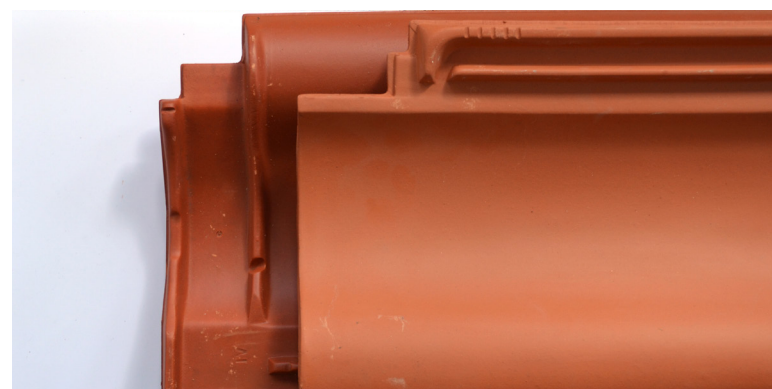

materialisatie 2A

MIDDENWEG 4 - FASE 1
01.07.2015



metselwerk, handvorm

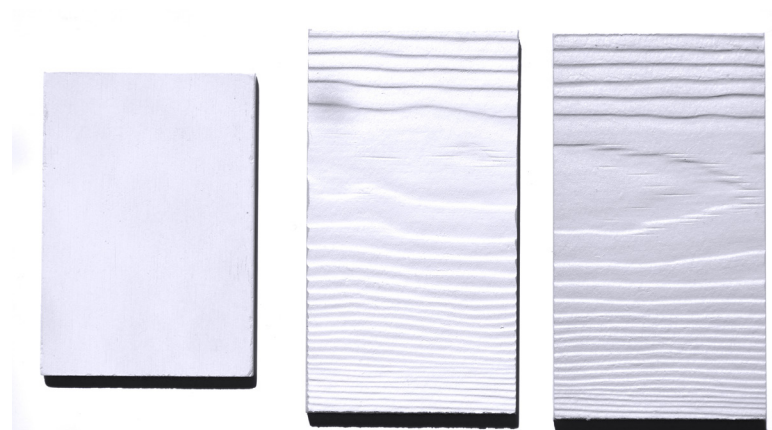

eternit, cedral



hout in kleur



keramische pan,
oudrood en natuurrood

materialisatie 2B

MIDDENWEG 4 - FASE 1
01.07.2015



metselwerk, handvorm

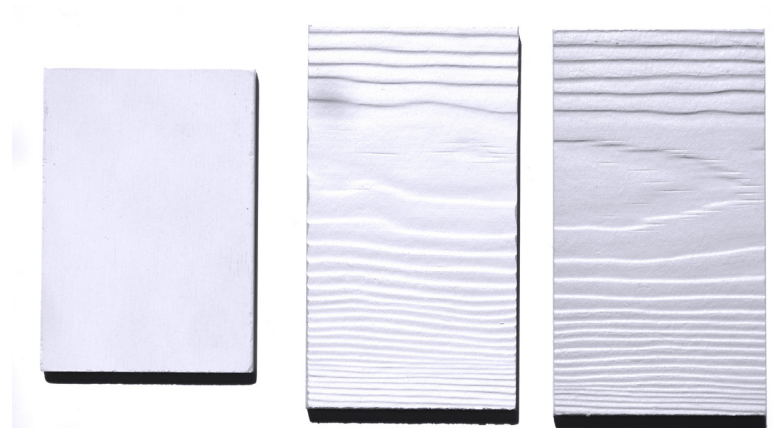

eternit, cedral



hout in kleur

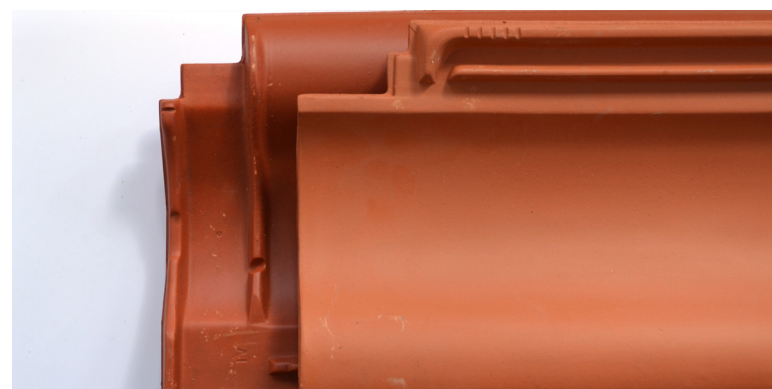
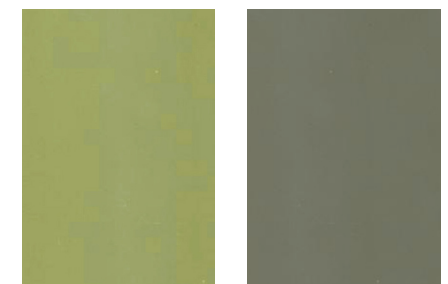

keramische pan,
oudrood en natuurrood

materialisatie DAC

MIDDENWEG 4 - FASE 1
01.07.2015



metselwerk, handvorm

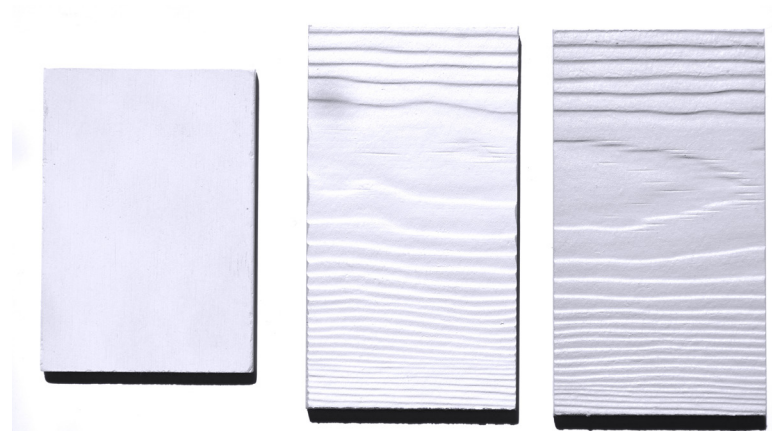

eternit, cedral



hout in kleur

